

Data sheet

Electric expansion valve

Type ETS 12.5 - ETS 400

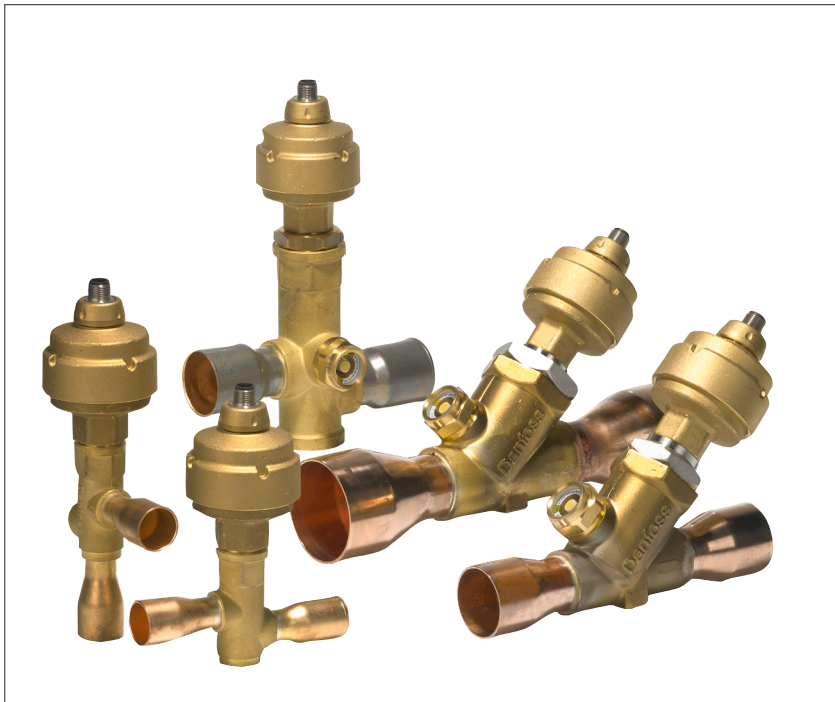

ETS is a series of electric expansion valves for precise liquid injection in evaporators for air conditioning and refrigeration applications.

The valve piston and linear positioning design is fully balanced, providing bi-flow feature as well as solenoid tight shut-off function in both flow directions.

The valve design uses bi-polar drive providing very precise flow regulation.

ETS valves are compatible with electronic control solutions from Danfoss and other manufacturers.

Features

- Precise positioning for optimal control of liquid injection.
- Wide range for all common refrigerants R22, R134a, R404A, R407A, R407C, R407F, R422B, R422D, R438A, R448A, R449A, R450A, R452A, R507, R513A, R410A, R1234ze and other refrigerants. Special valves for R744 (CO₂) are available.
- ETS 12.5, ETS25, ETS 50 and ETS100 provides working pressure of 45.5 bar / 660 psig and ETS 250, ETS 400 provides 34 bar / 493 psig.
- All ETS can be operated with flow in both directions and are solenoid tight.
- ETS 50 to ETS 400 have a balanced design.
- ETS 50 and ETS 100 feature improved process and productivity due to waterless brazing i.e soldering without wet cloth for cooling.
- Special ETS 250 and ETS 400 available for oil free applications.
- ETS 50 – ETS 400 are all designed with built-in sight glass with moisture indicator.
- Internal and external corrosion resistant design.
- Low power consumption.
- Cable and connector assemblies as accessories.
- EKC 316A, EKC 312 and EKD 316 are examples of Danfoss controllers with drivers matching the ETS needs.
- Danfoss EKE 1A, EKE 1B, EKE 1C, MCX061V, MCX152V are examples of Danfoss controllers with drivers matching the ETS needs.
- For manual operation and service of ETS valves an AST-g service driver is available.

Approvals

Technical data

Compatible refrigerants	Wide range for all common refrigerants R22, R134a, R404A, R407A, R407C, R407F, R422B, R422D, R438A, R448A, R449A, R450A, R452A, R507, R513A, R410A, R1234ze and other refrigerants. Special valves for R744 (CO2) are available. For other refrigerants, please contact your local Danfoss representative.
Refrigerant oil	All mineral oils and ester oils and special ETS 250 and ETS 400 support oil free applications
Comply with P.E.D.	Yes
Max. opening pressure differential (MOPD) normal flow	33 bar (478.6 psi)
Max. opening pressure differential (MOPD) reverse flow	ETS 12.5, ETS 25, ETS 50, ETS 100: 33 bar (478.6 psi) ETS 250, ETS 400: 10 bar (145 psi)
Max. working pressure (PS/MWP)	ETS 12.5, ETS 25, ETS 50, ETS 100: 45.5 bar (660 psig) ETS 250, ETS 400: 34 bar (493 psig)
Inlet fluid temperature	-40 °C – 65 °C (-40 °F – 149 °F). For higher temperature valve, please contact Danfoss.
Ambient temperature	-40 °C – 60 °C (-40 °F – 140 °F)
Material of Construction	ETS 50, ETS 100: Body and AST enclosure in brass, connections in bi-metal (stainless steel/copper). ETS 12.5, ETS 25, ETS 250, ETS 400: Body and AST enclosure in brass, connections in copper.
Motor enclosure	IP67
Stepper motor type	Bi-polar - permanent magnet.
Step mode	2 phase full step.
Phase resistance	52 Ω ±10%
Phase inductance	85 mH
Step angle	7.5° (motor), 0.9° (lead screw), Gearing ration 8.5:1. (38/13):1
Nominal voltage	Constant voltage drive: 12 V dc -4% – 15%, 150 steps/sec.
Phase current	Using chopper drive: 100 mA RMS -4% – 15%
Holding current	Constant voltage drive: Depends on application. Chopper drive: full current allowed (100% duty cycle)
Max. total power	Voltage / current drive: 5.5 / 1.3 W (UL: NEC class 2)
Step rate	Constant voltage drive: 150 steps/sec. Chopper current drive: 0 – 300 steps/sec. 300 recommended
Total steps	ETS 12.5, ETS 25, ETS 50: 2625 [160 / -0] steps ETS 100: 3530 [160 / -0] steps ETS 250, ETS 400: 3810 [160 / -0] steps
Full travel time	ETS 12.5, ETS 25, ETS 50: 17 / 8.5 sec. (voltage / current) ETS 100: 23 / 11.5 sec. (voltage / current) ETS 250, ETS 400: 25.4 / 12.7 sec. (voltage / current)
Lifting height	ETS 12.5, ETS 25, ETS 50: 13 mm (0.5 in.) ETS 100: 16 mm (0.6 in.) ETS 250, ETS 400: 17.2 mm (0.7 in.)
Reference position	Overdriving against the full close position
Electrical connection	M12 connector
Compatible Danfoss controllers	Danfoss EKE 1A, EKE 1B, EKE 1C, MCX061V, MCX152V and more

Electrical data
⚠ NOTE:

Full life time of standard ETS can only be ensured if oil is present in the system.
In oil-free systems, life time of the standard ETS cannot be guaranteed.
Oil free applications: Special ETS 250 and ETS 400 are available and for smaller capacities you can use ETS Colibri valves.

Data sheet | Electric expansion valve, type ETS 12.5 – ETS 400

Design

⚠ Note:
Flow direction from A to B
refers to the normal flow

1. M12 connection
2. Glass seal
3. AST motor housing
4. Stepper motor
5. Bearing
6. Spindle
7. Cone and lead nut
8. Valve seat

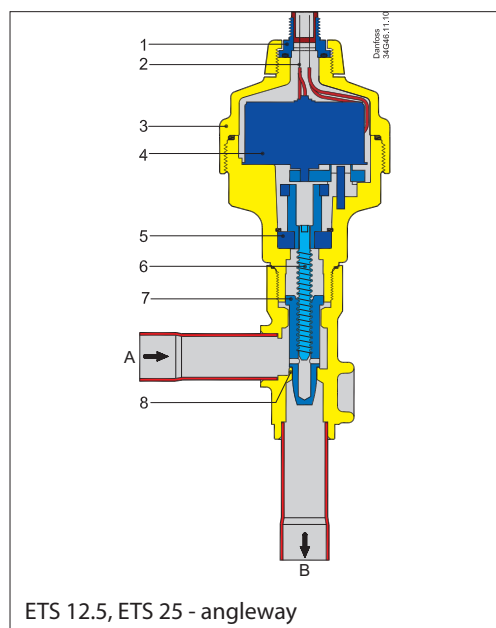
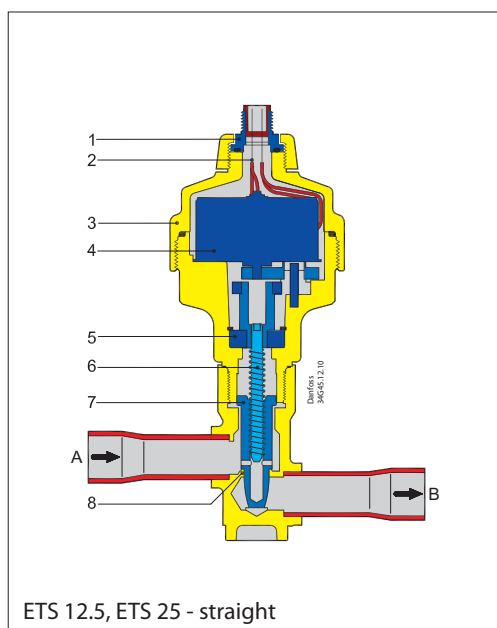

1. M12 connector
2. Glass seal
3. AST motor housing
4. Stepper motor
5. Bearing
6. Spindle
7. Top Nut
8. Valve piston
9. Valve seat
10. Valve cone

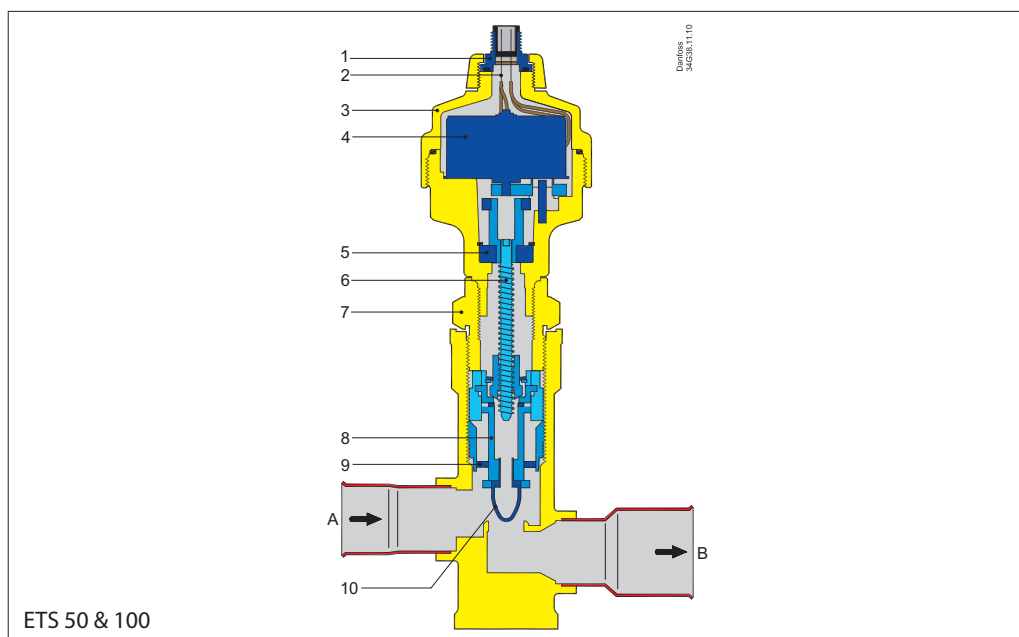

1. M12 connector
2. Glass seal
3. AST motor housing
4. Stepper motor
5. Bearing
6. Spindle
7. Top Nut
8. Valve piston
9. Sight glass with indicator
10. Valve seat
11. Valve cone

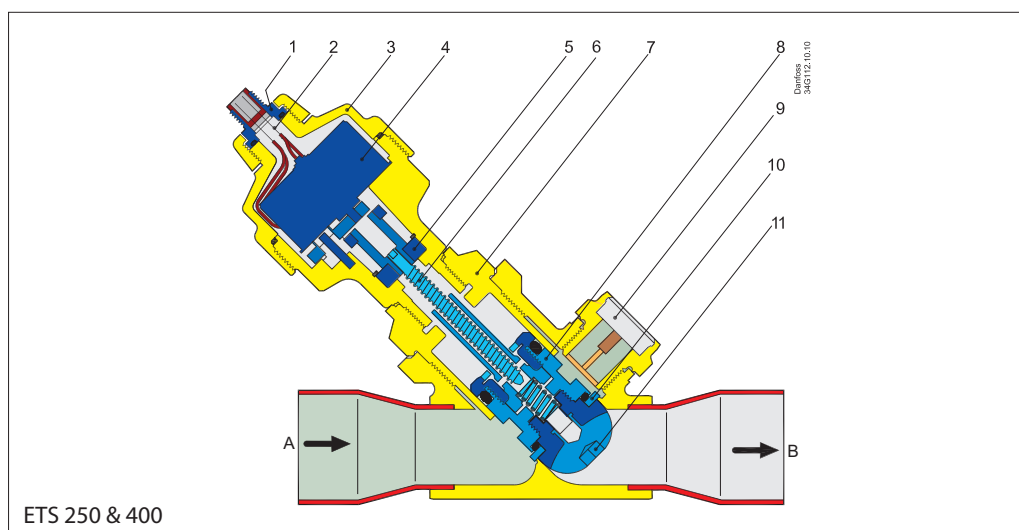

Data sheet | Electric expansion valve, type ETS 12.5 – ETS 400

Sight glass and indicator

ETS 50, ETS 100, ETS 250 and ETS 400 are equipped with sight glass with moisture indicator. The physical position of the piston in the valve can be checked through the sight glass. It also helps to determine the flow direction of the refrigerant in the system (ETS 50 and ETS 100).

Insufficient sub cooling can produce flash gas which is visible through the sight glass. The moisture indicator in the sight glass indicates dry or wet state of the refrigerant by changing its colour.

Electrical wiring

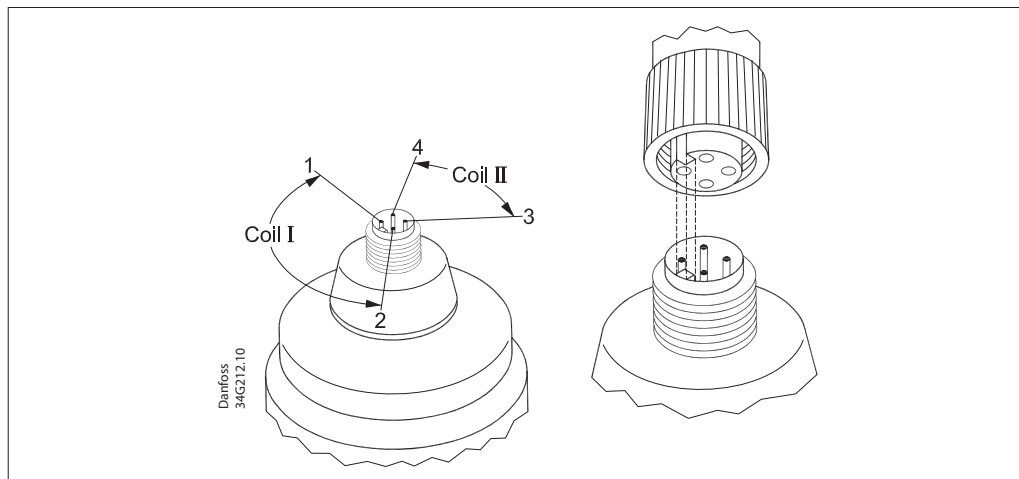

⚠ Note:

Electrical check of stepper motor and wiring: Coil I = 52 ohm, coil II = 52 ohm

Stepper motor switch sequence

	STEP	Coil I		Coil II		
		Red	Green	White	Black	
↑ CLOSING ↑	1	+	-	+	-	↓ OPENING ↓
	2	+	-	-	+	
	3	-	+	-	+	
	4	-	+	+	-	
	1	+	-	+	-	

If the controller driving the ETS valve is from another manufacturer than Danfoss or a custom design, the following points must be considered in order to overcome potential step loss.

a. To ensure total closing of the valve, the controller should have a function to overdrive the valve in the closing direction. It is recommended to overdrive ten percent of the full step range at appropriate intervals.

b. The amount of lost steps may increase as a function of the amount of changes of the opening degree. Such designed controller should be able to compensate the lost steps after a defined number of changes in opening degree.

⚠ Warning:

At power failure the ETS valve will remain in the opening position it has at the moment of power failure, unless a safety device in the form of a battery backup is installed.

Valve application

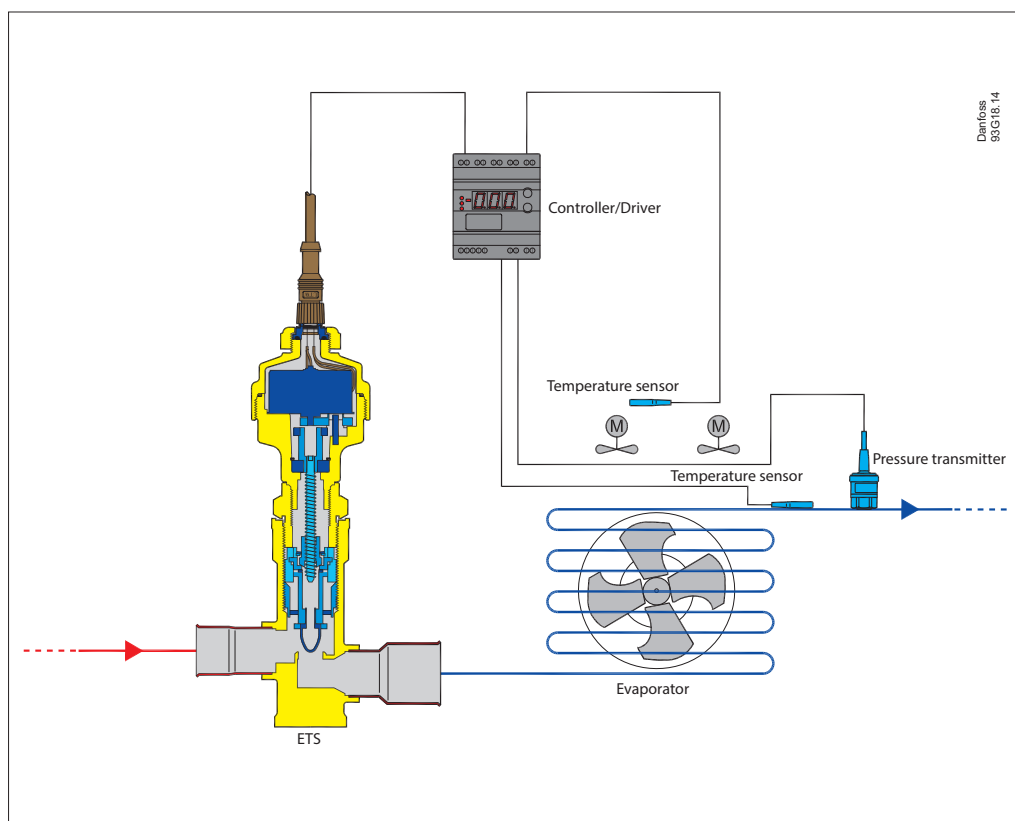

Valve operation

The ETS valves operate modulating by electronically controlled activation of the AST stepper motor. The motor is a type 2-phase bi-polar, which stays in position, unless power pulses from a driver initiate the two discrete sets of motor stator windings for rotation in either directions.

The direction of the rotation of the spindle depends on the phase relationship of the power pulses. This is decisive for the travel of the piston.

The motor is operating the spindle, whose rotating movements are transformed into linear motion by the transmission in the cage assembly.

The AST motor housing has a glass sealed M12 connection as standard, which can be connected with customized cable and plug/socket combinations.

The piston design inside the ETS valve is pressure balanced, giving identical bi-flow performance capabilities and nearby identical maximum capacities.

Closing the valve by overdriving, ensures that the reference number in steps is always correct.

Operating the ETS series requires a controller with either 12 V DC voltage drive (5.5 W) or using chopper current drive (100 mA RMS).

⚠ Note: Depending on the type of controller or driver, there will be limitations in cable length between valve actuator and driver.

Both the actual cable length, the level of EMC emission on the location and driver circuit has an impact on the actual distortion of the current to the actuator motor.

In order to increase max. cable length considerably, install a 10 mH filter type Danfoss AKA 211 on the four power terminals.

Please contact Danfoss for further information how and when to apply this countermeasure in cases with questionable cable length.

Data sheet | Electric expansion valve, type ETS 12.5 – ETS 400

Ordering ETS 12.5, ETS 25 Valve incl. actuator

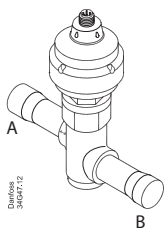

Type	Rated capacity ¹⁾									
	R410A		R407C		R22		R134a		R404A	
	[kW]	[TR]	[kW]	[TR]	[kW]	[TR]	[kW]	[TR]	[kW]	[TR]
ETS 12.5	70	20	63	18	57	16	45	13	43	12
ETS 25	144	41	129	37	117	34	93	27	88	25

Connection		
ODF × ODF (A × B)		Code no.
[in.]	[mm]	Straight way Single Pack
½ × ½	–	034G4209
–	12 × 12	034G4208
5/8 × 5/8	16 × 16	034G4210
7/8 × 7/8	22 × 22	034G4211
½ × ½	–	034G4201
–	12 × 12	034G4200
5/8 × 5/8	16 × 16	034G4202
7/8 × 7/8	22 × 22	034G4203

ETS 12.5 and ETS 25 do not feature sight glass

Type	Rated capacity ¹⁾									
	R410A		R407C		R22		R134a		R404A	
	[kW]	[TR]	[kW]	[TR]	[kW]	[TR]	[kW]	[TR]	[kW]	[TR]
ETS 12.5	70	20	63	18	57	16	45	13	43	12
ETS 25	144	41	129	37	117	34	93	27	88	25

Connection		
ODF × ODF (A × B)		Code no.
[in.]	[mm]	Angle way Single Pack
½ × ½	–	034G4213
–	12 × 12	034G4212
5/8 × 5/8	16 × 16	034G4214
7/8 × 7/8	22 × 22	034G4215
½ × ½	–	034G4205
–	12 × 12	034G4204
5/8 × 5/8	16 × 16	034G4206
7/8 × 7/8	22 × 22	034G4207

ETS 12.5 and ETS 25 do not feature sight glass

ETS 50, ETS 100 Valve incl. actuator

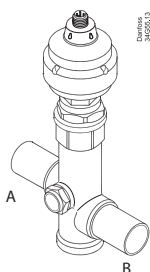

Type	Rated capacity ¹⁾									
	R410A		R407C		R22		R134a		R404A	
	[kW]	[TR]	[kW]	[TR]	[kW]	[TR]	[kW]	[TR]	[kW]	[TR]
ETS 50	262.3	75.7	240.5	69.1	215	62	170	48.9	161.4	46.3
ETS 100	488.4	140.9	447.8	128.7	400.4	115.4	316.5	91.2	300.5	86.6

Connection		
ODF × ODF (A × B)		Code no.
[in.]	[mm]	Single pack
7/8 × 7/8	22 × 22	034G1708
7/8 × 1 1/8	22 × 28	034G1705
1 1/8 × 1 1/8	28 × 28	034G1706
1 1/8 × 1 3/8	28 × 35	034G1704
1 1/8 × 1 1/8	28 × 28	034G0507
1 1/8 × 1 3/8	28 × 35	034G0501
1 3/8 × 1 3/8	35 × 35	034G0508
1 5/8 × 1 5/8	–	034G0505

ETS 50 and ETS 100 have integrated sight glass

ETS 250, ETS 400 Valve incl. actuator

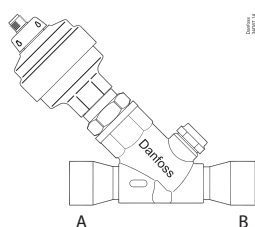

Type	Rated capacity ¹⁾									
	R410A		R407C		R22		R134a		R404A	
	[kW]	[TR]	[kW]	[TR]	[kW]	[TR]	[kW]	[TR]	[kW]	[TR]
ETS 250	–	–	1212	349	1106	319	874	252	828	239
ETS 400	–	–	1933	556	1764	509	1394	402	1320	381

Connection		
ODF × ODF (A × B)		Code no.
[in.]	[mm]	Single pack
1 1/8 × 1 1/8	28 × 28	034G2600
1 3/8 × 1 3/8	35 × 35	034G2601
1 5/8 × 1 5/8	–	034G2602
–	42 × 42	034G2611*
1 5/8 × 1 5/8	–	034G3500
2 1/8 × 2 1/8	54 × 54	034G3501

ETS 250 and ETS 400 have integrated sight glass except 034G2611.

¹⁾ The Rated capacity is based on:
 Evaporating temperature t_e: 5 °C / 40 °F
 Liquid temperature t_l: 28 °C / 82 °F
 Condensing temperature t_c: 32 °C / 90 °F
 Full stroke opening in normal flow direction

Data sheet | Electric expansion valve, type ETS 12.5 – ETS 400

ETS for oil free applications Valve incl. actuator

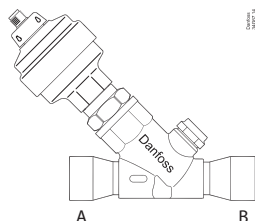

Type	Rated capacity ¹⁾									
	R410A		R407C		R22		R134a		R404A	
	[kW]	[TR]	[kW]	[TR]	[kW]	[TR]	[kW]	[TR]	[kW]	[TR]
Oil free ETS 250	-	-	1212	349	1106	319	874	252	828	239
Oil free ETS 400	-	-	1933	556	1764	509	1394	402	1320	381

Connection		
ODF × ODF (A × B)		Code no.
[in.]	[mm]	Single pack
1 3/8 × 1 3/8	35 × 35	034G2625
1 5/8 × 1 5/8	-	034G2626
1 5/8 × 1 5/8	-	034G3514
2 1/8 × 2 1/8	54 × 54	034G3515

¹⁾ The Rated capacity is based on:
 Evaporating temperature t_e : 5 °C / 40 °F
 Liquid temperature t_l : 28 °C / 82 °F
 Condensing temperature t_c : 32 °C / 90 °F
 Full stroke opening in normal flow direction

ETS 250 and ETS 400 have integrated sight glass

For smaller capacities of ETS oil free valves see ETS Colibri

ETS for R744 Applications

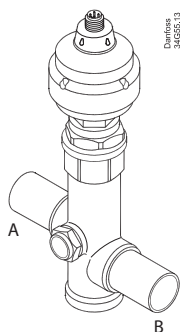

Type	Connection	
	ODF × ODF (A × B) [in.]	Code no. Single pack
ETS 12.5	7/8 × 7/8 in	034G4220
ETS 25	7/8 × 7/8 in	034G4219
ETS 50	1 1/8 × 1 1/8 in	034G1714
ETS 100	1 1/8 × 1 1/8 in	034G0515

ETS 50 and ETS 100 have integrated sight glass

ETS for R744 can be use as loading/unloading valve

ETS for R744 Applications (PS/MWP = 45.5 bar / 660 psig)

For capacities, please contact Danfoss.



Coolselector2®

For easy and precise selection of valve, use Danfoss' CoolSelector2® software. You can find the ETS valves on the group, "Electronic expansion valves".
 You can download it from <http://coolselector.danfoss.com>

Spare parts

Cone/piston for ETS 12.5 / ETS 25

Items	Description	Quantity	Code no.
		[pcs]	
	Cone/piston for ETS 12.5 + metal gasket	1	034G2345
	Cone/piston for ETS 25 + metal gasket	1	034G2346

Actuator with integrated M12 connection

Items	Description	Quantity	Code no.
		[pcs]	
	Actuator with integrated M12 with Ceramic bearing (incl. metal gasket) for ETS 12.5, ETS 25	1	034G2088
	Actuator with integrated M12 with ceramic bearing (incl. metal gasket) for ETS 25B, ETS 50, ETS 100, ETS 250, ETS 400	1	034G2087
	Metal Gasket	1	034G2344

Data sheet | Electric expansion valve, type ETS 12.5 – ETS 400

Accessories: M12 angle cable

M12 angle female connector is intended for use with a standard M12 male connector, available on stepper motor valves.
This cable is designed to offer high flexibility and small outer diameters with tensile strength. The angle way M12 cable consist of paired, twisted wires, which decreases mutual influence between signals transmitted along the cable and reduces influence of external sources of interference. The cables thus provides a higher degree of protection against lost steps compared to other cables.

Approvals



Specification

Jacket	PVC - black
Cable outer sheath	Oil - resistant
Water proof rating	IP 67
Operating temperature range	-40 – +80 °C
Wire type	Twisted pair, cross section 20 AWG / 0.5 mm ²
Cable outer diameter	7.0 mm
Minimum bending radius	10 x cable diameter
Cable combustibility / test	Flame retardant / VW-1 / CSA FT - 1
M12 standard	EN 61076-2-101
Reference standard	UL style 2464 and DIN VDE 0812
LVD directive	2014/35/EU

Ordering

Cable	Cable length (L)	Insulation	Packing format	Code no.
PVC - black	2 m / 6.6 ft	SR-PVC	Single pack	034G7073
	8 m / 26.2 ft	SR-PVC	Single pack	034G7074

Identification

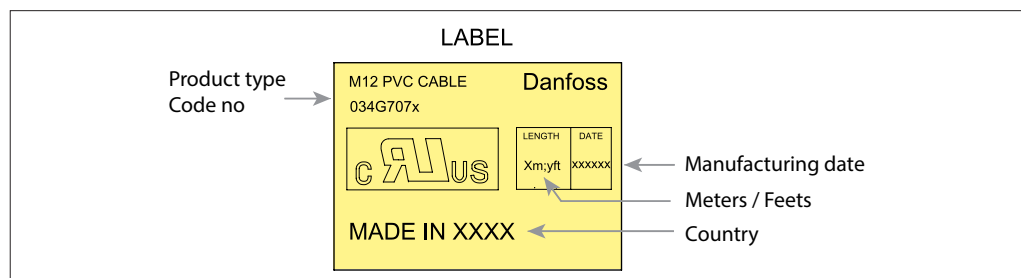

Connections

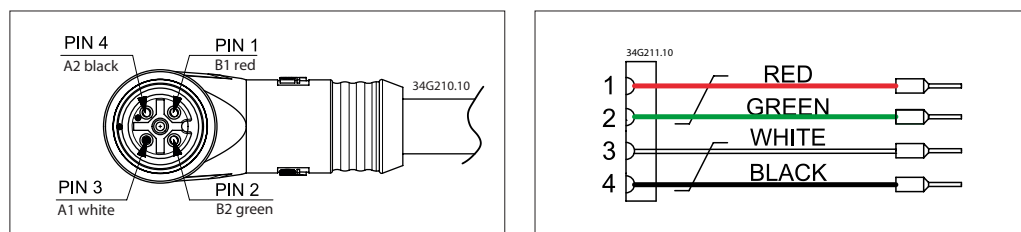

Dimensions

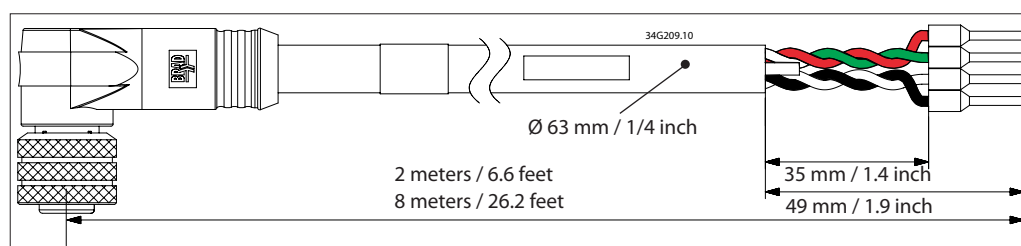

Data sheet | Electric expansion valve, type ETS 12.5 – ETS 400

Valve sizing

For optimum performance, it is important to correct the evaporator capacity. Selection is also dependent on an acceptable pressure drop across the valve. The evaporator capacity must be corrected if sub cooling deviates from 4K / 7.2 °F. In order to select the correct size of ETS you will need the following information:

Refrigerant: R410A, R407C, R404A, R507, R134a, R22, R1234ze

- Evaporator capacity Q_e in [kW] or [TR]
- Evaporating temperature t_e in [°C] or [°F]
- Condensing temperature t_c in [°C] or [°F]
- Max. acceptable pressure drop in the ETS valve in [bar] or [psi] Δp
- Sub cooling Δt_{sub}
- Connection size

Valve selection

Example

When selecting the valve it may be necessary to apply a correction factor to the actual evaporator capacity. This correction factor is required when system conditions are different from table conditions. Selection also depends on having an acceptable pressure drop across the valve. The following example illustrates correct selection of the valve.

Refrigerant: R410A

- Evaporator capacity: $Q_e = 500 \text{ kW} / 143 \text{ TR}$
- Condensing temperature: $t_c = 25 \text{ °C} / 77 \text{ °F}$
- Condensing pressure: $p_c = 23 \text{ bar} / 330 \text{ psig}$
- Evaporating temperature: $t_e = +10 \text{ °C} / 50 \text{ °F}$
- Evaporating pressure: $p_e = 9.8 \text{ bar} / 142 \text{ psig}$
- Liquid Line Loss: $p_l = 0.5 \text{ bar}$ (estimate)
- Max. Pressure drop in the valve:
 $\Delta p = p_c - p_l - p_e = 23 - 0.5 - 9.8 = 12.7 \text{ bar} / 184 \text{ psi}$
- Connection size: $1\frac{1}{8} \times 1\frac{1}{8} \text{ in.}$

Step 1

Determine the correction factor for sub cooling Δt_{sub} .

From the correction factors table (see below) a sub cooling of 15K / 27 °F, R410A corresponds to a factor of 1.15.

Correction factors for sub cooling Δt_{sub} .

Connection factor	Δt_{sub}									
	4 K	10 K	15 K	20 K	25 K	30 K	35 K	40 K	45 K	50 K
	7.2 °F	18 °F	27 °F	36 °F	45 °F	54 °F	63 °F	72 °F	81 °F	90 °F
R22	1.00	1.06	1.1	1.15	1.20	1.25	1.30	1.35	1.39	1.44
R410A	1.00	1.00	1.15	1.21	1.27	1.33	1.39	1.45	1.50	1.56
R407C	1.00	1.08	1.14	1.21	1.27	1.33	1.39	1.45	1.51	1.57
R134a	1.00	1.08	1.13	1.19	1.25	1.31	1.37	1.42	1.48	1.54
R404A/R507	1.00	1.10	1.20	1.29	1.37	1.46	1.54	1.63	1.70	1.78

Step 2

Corrected evaporator capacity is

$$Q_e (\text{Corrected}) = 500 \text{ kW} / 1.15 = 435 \text{ kW} (124 \text{ TR})$$

Step 3

Now select the appropriate capacity table, R410A, and choose the column for an evaporating temperature of $t_e = 10 \text{ °C} / 50 \text{ °F}$.

Using the corrected evaporator capacity, select a valve that provides an equivalent or greater capacity at an acceptable pressure drop across the valve of 12.7 bar / 184 psi.

ETS 100 delivers 503.8 kW / 143 TR at 14 bar which is slightly higher than 12.7 bar / 184 psi pressure drop across the valve. Based on the required connection size of $1\frac{1}{8} \text{ in.}$, the ETS 100 is the proper selection for this example.

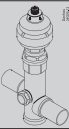
	t_e [°C]	Rated capacity [kW] in the normal flow direction															
		ETS 50								ETS 100							
		Pressure drop Δp [bar]															
		2	4	6	8	10	12	14	16	2	4	6	8	10	12	14	16
R410A	-40	173.7	224.6	255.1	275.5	289.5	299.2	305.7	309.6	323.5	418.1	475.0	512.9	539.1	557.2	569.2	576.4
	-30	169.3	220.8	252.3	273.5	288.3	298.6	305.7	310.1	315.2	411.2	469.7	509.2	536.8	556.1	569.2	577.5
	-20	163.3	214.9	246.8	268.6	284.1	295.0	302.5	307.4	304.0	400.1	459.6	500.2	528.9	549.2	563.3	572.4
	-10	155.9	206.8	238.8	260.9	276.6	287.9	295.8	301.0	290.3	385.0	444.6	485.7	515.1	536.1	550.8	560.5
	10	127.5	184.5	214.8	236.1	251.5	262.7	270.6	275.8	256.0	343.5	399.0	439.6	469.2	489.1	503.8	513.6

Step 4

ETS 100, $1\frac{1}{8} \times 1\frac{1}{8} \text{ in.}$ connection size:

Single pack code no. 034G0507.

⚠ Note:

For easy and precise selection of valve, use Danfoss' CoolSelector software. You can download it from <http://www.danfoss.com/businessareas/refrigerationandairconditioning/product+selection+tools+details/coolselector.htm>

Data sheet | Electric expansion valve, type ETS 12.5 – ETS 400

Correction for subcooling

 Δt_{sub}

The evaporator capacities used must be corrected if subcooling deviates from 4 K / 7.2 °F.

The corrected capacity can be obtained by dividing the required evaporator capacity by the correction factor. Selections can then be made from the tables below.

Correction factor	Δt_{sub}									
	4 K	10 K	15 K	20 K	25 K	30 K	35 K	40 K	45 K	50 K
	7.2 °F	18 °F	27 °F	36 °F	45 °F	54 °F	63 °F	72 °F	81 °F	90 °F
R22	1.00	1.06	1.11	1.15	1.20	1.25	1.30	1.35	1.39	1.44
R410A	1.00	1.08	1.15	1.21	1.27	1.33	1.39	1.45	1.50	1.56
R407C	1.00	1.08	1.14	1.21	1.27	1.33	1.39	1.45	1.51	1.57
R134a	1.00	1.08	1.13	1.19	1.25	1.31	1.37	1.42	1.48	1.54
R404A / R507	1.00	1.10	1.20	1.29	1.37	1.46	1.54	1.63	1.70	1.78



Note:

Insufficient subcooling can produce flash gas.

Rated Capacity [kW]

SI units

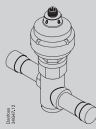
	t_e [°C]	Rated capacity [kW] in the normal flow direction															
		ETS 12.5								ETS 25							
		Pressure drop Δp [bar]															
		2	4	6	8	10	12	14	16	2	4	6	8	10	12	14	16
R410A	-40	46.4	60.0	68.1	73.5	77.3	79.9	81.6	82.6	95.3	123.2	140.0	151.1	158.8	164.1	167.7	169.8
	-30	45.2	59.0	67.3	73.0	76.9	79.7	81.6	82.7	92.9	121.2	138.4	150.0	158.1	163.8	167.7	170.1
	-20	43.6	57.4	65.9	71.7	75.8	78.7	80.7	82.0	89.6	117.9	135.4	147.4	155.8	161.8	165.9	168.6
	-10	41.6	55.2	63.7	69.6	73.8	76.8	78.9	80.3	85.5	113.5	131.0	143.1	151.7	157.9	162.2	165.0
	-5	40.5	53.9	62.4	68.3	72.5	75.5	77.6	79.0	83.3	110.8	128.2	140.3	149.0	155.2	159.6	162.5
	10	36.7	49.2	57.3	63.0	67.1	70.1	72.2	73.5	75.4	101.2	117.8	129.5	137.9	144.0	148.3	151.2
R407C	-40	42.1	52.8	58.6	62.0	63.9	64.9	65.0	64.6	86.5	108.5	120.5	127.5	131.4	133.3	133.6	132.7
	-30	41.9	53.0	59.2	63.0	65.2	66.3	66.7	66.4	86.0	109.0	121.7	129.4	133.9	136.3	137.1	136.6
	-20	41.2	52.8	59.3	63.4	65.8	67.2	67.8	67.8	84.7	108.5	121.9	130.2	135.3	138.2	139.4	139.3
	-10	40.2	52.0	58.8	63.1	65.9	67.5	68.3	68.4	82.6	106.9	120.9	129.8	135.4	138.7	140.3	140.6
	-5	39.6	51.4	58.4	62.8	65.6	67.3	68.2	68.4	81.3	105.7	120.0	129.0	134.9	138.4	140.2	140.6
	10	37.1	48.9	56.0	60.6	63.7	65.5	66.7	67.1	76.3	100.5	115.0	124.6	130.9	134.8	137.1	138.0
R22	-40	40.2	51.3	57.9	62.1	65.0	66.9	68.0	68.6	82.6	105.5	118.9	127.7	133.6	137.5	139.8	141.1
	-30	39.8	51.3	58.1	62.6	65.7	67.7	69.1	69.8	81.8	105.4	119.4	128.7	135.0	139.2	142.0	143.5
	-20	39.1	50.8	57.9	62.6	65.9	68.1	69.6	70.4	80.3	104.4	118.9	128.7	135.4	140.0	143.0	144.8
	-10	38.0	49.9	57.1	62.1	65.5	67.9	69.5	70.5	78.1	102.5	117.4	127.5	134.6	139.5	142.8	144.9
	-5	37.4	49.3	56.6	61.6	65.1	67.5	69.2	70.2	76.9	101.2	116.3	126.5	133.7	138.8	142.2	144.4
	10	35.2	46.8	54.1	59.2	62.9	65.4	67.2	68.4	72.3	96.2	111.3	121.7	129.2	134.5	138.2	140.6
R134a	-40	35.6	43.2	46.8	48.5	49.0	48.6	47.7	46.3	73.1	88.8	96.3	99.7	100.7	100.0	98.0	95.1
	-30	35.8	44.0	48.0	50.0	50.7	50.6	49.9	48.6	73.5	90.4	98.6	102.7	104.2	104.0	102.5	99.9
	-20	35.6	44.3	48.8	51.1	52.1	52.2	51.7	50.6	73.3	91.1	100.2	105.0	107.0	107.3	106.2	104.0
	-10	35.2	44.3	49.1	51.7	53.0	53.3	53.0	52.1	72.3	91.0	100.9	106.2	108.8	109.6	108.9	107.1
	-5	34.8	44.1	49.0	51.8	53.2	53.7	53.4	52.6	71.6	90.6	100.8	106.4	109.3	110.3	109.8	108.2
	10	33.3	42.8	48.1	51.2	53.0	53.7	53.8	53.2	68.3	88.0	98.9	105.3	108.9	110.4	110.5	109.4
R404A	-40	31.9	39.6	43.4	45.2	45.9	45.8	45.0	43.8	65.7	81.4	89.2	93.0	94.3	94.0	92.5	90.0
	-30	31.5	39.5	43.6	45.8	46.7	46.7	46.2	45.1	64.7	81.2	89.7	94.0	95.9	96.1	94.9	92.8
	-20	30.7	39.0	43.3	45.7	46.9	47.1	46.8	45.9	63.0	80.1	89.1	94.0	96.3	96.9	96.1	94.3
	-10	29.5	37.9	42.5	45.1	46.4	46.9	46.7	45.9	60.7	78.0	87.4	92.7	95.4	96.3	95.9	94.4
	-5	28.9	37.3	41.9	44.6	46.0	46.5	46.3	45.6	59.4	76.6	86.1	91.6	94.5	95.5	95.2	93.8
	10	26.5	34.6	39.2	41.9	43.5	44.1	44.1	43.5	54.4	71.0	80.5	86.2	89.3	90.6	90.6	89.4

Data sheet | Electric expansion valve, type ETS 12.5 – ETS 400

Rated Capacity [kW]

SI units

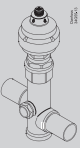
	t _e [°C]	Rated capacity [kW] in the normal flow direction															
		ETS 50								ETS 100							
		Pressure drop Δp [bar]															
		2	4	6	8	10	12	14	16	2	4	6	8	10	12	14	16
R410A	-40	173.7	224.6	255.1	275.5	289.5	299.2	305.7	309.6	323.5	418.1	475.0	512.9	539.1	557.2	569.2	576.4
	-30	169.3	220.8	252.3	273.5	288.3	298.6	305.7	310.1	315.2	411.2	469.7	509.2	536.8	556.1	569.2	577.5
	-20	163.3	214.9	246.8	268.6	284.1	295.0	302.5	307.4	304.0	400.1	459.6	500.2	528.9	549.2	563.3	572.4
	-10	155.9	206.8	238.8	260.9	276.6	287.9	295.8	301.0	290.3	385.0	444.6	485.7	515.1	536.1	550.8	560.5
	-5	151.7	202.0	233.7	255.8	271.6	283.0	291.0	296.4	282.5	376.0	435.2	476.3	505.8	527.0	541.9	551.8
	10	137.5	184.5	214.8	236.1	251.5	262.7	270.6	275.8	256.0	343.5	399.9	439.6	468.3	489.1	503.8	513.6
R407C	-40	158.5	199.3	222.0	235.6	243.8	248.1	249.7	249.1	295.1	371.2	413.3	438.7	453.9	462.0	464.9	463.8
	-30	157.6	200.3	224.4	239.3	248.5	253.7	256.1	256.2	293.5	373.0	417.8	445.5	462.6	472.5	476.9	477.1
	-20	155.3	199.5	224.9	241.0	251.2	257.3	260.5	261.3	289.2	371.5	418.8	448.7	467.7	479.2	485.1	486.6
	-10	151.7	196.8	223.3	240.4	251.5	258.5	262.5	263.9	282.4	366.4	415.9	447.6	468.4	481.4	488.7	491.4
	-5	149.4	194.7	221.7	239.2	250.8	258.1	262.4	264.2	278.1	362.6	412.8	445.4	466.9	480.6	488.6	491.9
	10	140.7	185.7	213.2	231.6	244.0	252.3	257.4	259.9	261.9	345.7	397.0	431.2	454.4	469.8	479.2	483.9
R22	-40	151.5	193.5	218.1	234.2	245.1	252.2	256.6	258.8	282.1	360.2	406.2	436.2	456.3	469.6	477.7	481.9
	-30	149.9	193.2	218.9	236.0	247.6	255.4	260.4	263.1	279.1	359.7	407.6	439.4	460.9	475.5	484.8	489.9
	-20	147.1	191.3	218.0	235.9	248.2	256.6	262.2	265.5	273.9	356.2	405.9	439.2	462.1	477.9	488.2	494.3
	-10	143.2	187.8	215.2	233.8	246.7	255.7	261.8	265.6	266.6	349.7	400.8	435.3	459.4	476.2	487.5	494.5
	-5	140.8	185.5	213.1	231.9	245.1	254.4	260.7	264.6	262.3	345.4	396.8	431.8	456.4	473.7	485.4	492.8
	10	132.4	176.2	203.9	223.0	236.7	246.5	253.2	257.6	246.5	328.1	379.6	415.3	440.8	458.9	471.5	479.7
R134a	-40	133.1	161.8	175.4	181.6	183.4	182.1	178.6	173.3	247.8	301.3	326.6	338.2	341.5	339.1	332.5	322.6
	-30	133.9	164.7	179.7	187.1	189.9	189.5	186.7	182.1	249.3	306.6	334.6	348.5	353.6	352.8	347.6	339.0
	-20	133.4	166.1	182.6	191.2	195.0	195.4	193.4	189.5	248.4	309.2	340.0	356.0	363.1	363.9	360.1	352.8
	-10	131.7	165.9	183.7	193.5	198.3	199.6	198.3	195.1	245.2	308.8	342.1	360.3	369.2	371.6	369.3	363.3
	-5	130.3	165.1	183.6	193.9	199.2	200.9	200.0	197.1	242.6	307.4	341.9	361.1	370.8	374.1	372.4	367.0
	10	124.5	160.3	180.2	191.9	198.3	201.2	201.3	199.3	231.8	298.5	335.5	357.2	369.3	374.6	374.8	371.1
R404A	-40	119.8	148.6	162.8	169.8	172.3	171.9	169.2	164.7	223.0	276.6	303.1	316.1	320.9	320.0	315.0	306.7
	-30	118.0	148.2	163.7	171.7	175.2	175.6	173.6	169.8	219.7	276.0	304.7	319.7	326.2	326.9	323.2	316.1
	-20	115.0	146.1	162.6	171.6	176.0	177.1	175.7	172.5	214.0	272.1	302.8	319.6	327.6	329.7	327.2	321.3
	-10	110.8	142.3	159.5	169.3	174.4	176.1	175.4	172.7	206.3	265.0	297.1	315.2	324.6	327.9	326.6	321.5
	-5	108.3	139.8	157.2	167.3	172.6	174.6	174.1	171.7	201.7	260.3	292.7	311.4	321.4	325.1	324.2	319.7
	10	99.4	129.7	147.1	157.5	163.3	165.8	165.8	163.7	185.0	241.6	273.9	293.2	304.0	308.7	308.6	304.8

The capacities stated in the tables are for the normal flow direction. For ETS 50 and 100 specifically, the capacity in reverse flow direction varies between 90% and 125% of the capacity in normal flow direction.

Rated Capacity [kW]

SI units

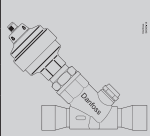
	t_e [°C]	Rated capacity [kW] in the normal flow direction															
		ETS 250								ETS 400							
		Pressure drop Δp [bar]															
		2	4	6	8	10	12	14	16	2	4	6	8	10	12	14	16
R407C	-40	811	1017	1129	1195	1232	1249	1252	1244	1294	1622	1801	1905	1964	1992	1997	1984
	-30	806	1022	1141	1213	1255	1277	1284	1280	1286	1629	1820	1934	2002	2037	2049	2041
	-20	794	1017	1143	1220	1268	1295	1306	1305	1266	1621	1823	1947	2023	2065	2083	2082
	-10	774	1002	1133	1216	1269	1300	1315	1317	1235	1598	1808	1940	2024	2073	2097	2101
	-5	762	990	1124	1209	1264	1297	1314	1318	1215	1580	1793	1929	2016	2068	2095	2102
	10	715	941	1078	1167	1226	1264	1285	1293	1141	1502	1719	1862	1956	2016	2049	2062
R22	-40	779	995	1122	1205	1261	1297	1320	1331	1243	1587	1790	1922	2011	2069	2105	2123
	-30	771	994	1126	1214	1273	1314	1339	1353	1230	1585	1796	1936	2031	2095	2136	2159
	-20	757	984	1121	1213	1277	1320	1349	1366	1207	1569	1789	1935	2036	2106	2151	2178
	-10	737	966	1107	1202	1269	1315	1347	1366	1175	1541	1766	1918	2024	2098	2148	2179
	-5	724	954	1096	1193	1261	1309	1341	1361	1156	1522	1748	1903	2011	2087	2139	2171
	10	681	906	1049	1147	1218	1268	1303	1325	1086	1446	1673	1830	1942	2022	2078	2114
R134a	-40	684	832	902	934	943	937	919	891	1092	1328	1439	1490	1505	1494	1465	1422
	-30	688	847	924	963	977	975	960	937	1098	1351	1474	1535	1558	1555	1532	1494
	-20	686	854	939	983	1003	1005	995	975	1094	1362	1498	1569	1600	1603	1587	1555
	-10	677	853	945	995	1020	1027	1020	1003	1080	1360	1507	1587	1627	1637	1627	1600
	-5	670	849	944	997	1024	1033	1029	1014	1069	1354	1506	1591	1634	1648	1641	1617
	10	640	824	927	987	1020	1035	1035	1025	1021	1315	1478	1574	1627	1650	1651	1635
R404A	-40	615	763	836	871	884	881	867	844	981	1217	1333	1390	1410	1406	1383	1346
	-30	606	761	840	881	899	900	890	870	967	1214	1340	1406	1434	1436	1419	1387
	-20	591	750	835	881	903	908	901	884	942	1197	1332	1405	1440	1448	1437	1410
	-10	569	731	819	869	894	903	899	884	908	1166	1306	1386	1426	1440	1433	1411
	-5	556	718	807	858	885	895	892	879	887	1145	1287	1369	1412	1428	1423	1402
	10	510	666	755	807	837	849	849	838	814	1062	1204	1288	1335	1355	1354	1336

Data sheet | Electric expansion valve, type ETS 12.5 – ETS 400

Rated Capacity [TR]
(TR = ton of refrigeration)

US units

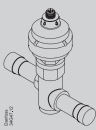
	t_e [°F]	Rated capacity [TR] in the normal flow direction															
		ETS 12.5								ETS 25							
		Pressure drop Δp [psi]															
		40	60	80	100	125	150	175	200	40	60	80	100	125	150	175	200
R410A	-40	14.9	17.2	18.9	20.1	21.3	22.1	22.7	23.2	30.7	35.5	38.8	41.4	43.7	45.5	46.7	47.6
	-20	14.6	16.9	18.6	19.9	21.1	22.0	22.7	23.1	29.9	34.8	38.3	40.9	43.4	45.2	46.6	47.6
	0	14.0	16.4	18.1	19.4	20.7	21.6	22.3	22.8	28.8	33.7	37.2	39.9	42.5	44.4	45.9	46.9
	20	13.3	15.7	17.4	18.7	20.0	20.9	21.6	22.2	27.4	32.2	35.7	38.4	41.0	43.0	44.5	45.5
	40	12.5	14.7	16.4	17.7	18.9	19.9	20.6	21.1	25.7	30.3	33.7	36.4	38.9	40.9	42.3	43.4
	50	12.0	14.2	15.8	17.1	18.3	19.2	19.9	20.5	24.7	29.2	32.5	35.1	37.6	39.6	41.0	42.1
R407C	-40	13.4	15.2	16.3	17.2	17.8	18.2	18.4	18.5	27.5	31.2	33.6	35.3	36.7	37.5	37.9	38.0
	-20	13.4	15.2	16.5	17.4	18.2	18.6	18.9	19.0	27.5	31.3	33.9	35.8	37.3	38.3	38.8	39.1
	0	13.2	15.1	16.5	17.4	18.3	18.8	19.2	19.3	27.1	31.1	33.9	35.9	37.6	38.7	39.4	39.7
	20	12.8	14.8	16.3	17.3	18.2	18.8	19.2	19.4	26.4	30.5	33.4	35.5	37.4	38.6	39.4	39.9
	40	12.4	14.4	15.8	16.9	17.8	18.5	18.9	19.2	25.4	29.5	32.5	34.7	36.6	38.0	38.9	39.4
	50	12.1	14.1	15.5	16.6	17.5	18.2	18.7	18.9	24.8	28.9	31.9	34.1	36.1	37.4	38.4	38.9
R22	-40	12.9	14.8	16.1	17.1	18.0	18.6	19.0	19.3	26.5	30.3	33.1	35.1	36.9	38.2	39.1	39.7
	-20	12.8	14.7	16.1	17.2	18.1	18.8	19.3	19.6	26.3	30.3	33.1	35.3	37.2	38.7	39.7	40.4
	0	12.6	14.6	16.0	17.1	18.1	18.8	19.4	19.8	25.8	29.9	32.9	35.1	37.2	38.7	39.8	40.6
	20	12.2	14.2	15.7	16.8	17.9	18.7	19.3	19.7	25.1	29.3	32.3	34.6	36.8	38.4	39.6	40.4
	40	11.7	13.8	15.3	16.4	17.5	18.3	18.9	19.3	24.1	28.3	31.4	33.7	35.9	37.6	38.9	39.7
	50	11.5	13.5	15.0	16.1	17.2	18.0	18.6	19.1	23.6	27.7	30.8	33.1	35.4	37.4	38.3	39.2
R134a	-40	11.2	12.4	13.1	13.6	13.9	13.9	13.8	13.6	22.9	25.5	27.0	27.9	28.5	28.6	28.4	27.9
	-20	11.3	12.6	13.5	14.0	14.3	14.5	14.5	14.3	23.2	26.0	27.7	28.8	29.5	29.8	29.7	29.3
	0	11.3	12.7	13.7	14.3	14.7	14.9	14.9	14.8	23.2	26.2	28.1	29.3	30.2	30.6	30.7	30.4
	20	11.2	12.7	13.7	14.4	14.9	15.1	15.2	15.2	22.9	26.1	28.1	29.5	30.6	31.1	31.3	31.2
	40	10.9	12.5	13.5	14.3	14.8	15.2	15.3	15.3	22.4	25.6	27.8	29.3	30.5	31.2	31.5	31.5
	50	10.7	12.3	13.4	14.1	14.8	15.3	15.1	15.3	22.0	25.3	27.5	29.1	30.3	31.1	31.4	31.4
R404A	-40	10.1	11.4	12.1	12.6	12.9	13.1	13.0	12.8	20.8	23.4	25.0	25.9	26.6	26.8	26.7	26.4
	-20	10.0	11.3	12.2	12.7	13.1	13.3	13.3	13.2	20.6	23.3	25.0	26.2	27.0	27.3	27.4	27.1
	0	9.8	11.1	12.0	12.6	13.1	13.4	13.4	13.3	20.0	22.9	24.8	26.0	27.0	27.4	27.5	27.4
	20	9.4	10.8	11.7	12.4	12.9	13.2	13.3	13.2	19.3	22.2	24.1	25.4	26.5	27.0	27.3	27.2
	40	8.9	10.3	11.2	11.9	12.4	12.7	12.9	12.8	18.2	21.1	23.0	24.4	25.5	26.1	26.4	26.4
	50	8.6	9.9	10.9	11.5	12.1	12.4	12.5	12.5	17.6	20.4	22.4	23.7	24.9	25.5	25.8	25.8

Data sheet | Electric expansion valve, type ETS 12.5 – ETS 400

Rated Capacity [TR]
(TR = ton of refrigeration)

US units

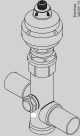
	t _e [°F]	Rated capacity [TR] in the normal flow direction															
		ETS 50								ETS 100							
		Pressure drop Δp [psi]															
		40	60	80	100	125	150	175	200	40	60	80	100	125	150	175	200
R410A	-40	55.9	64.6	70.8	75.4	79.7	82.9	85.2	86.8	104.2	120.3	131.8	140.4	148.5	154.4	158.6	161.6
	-20	54.6	63.4	69.8	74.6	79.1	82.5	85.0	86.7	101.6	118.0	129.9	138.9	147.4	153.6	158.2	161.5
	0	52.6	61.4	67.9	72.8	77.5	81.0	83.6	85.5	97.8	114.3	126.4	135.6	144.3	150.9	155.7	159.2
	20	49.9	58.7	65.1	70.1	74.8	78.4	81.1	83.1	93.0	109.2	121.2	130.4	139.3	146.0	151.0	154.6
	40	46.8	55.2	61.4	66.3	71.0	74.6	77.2	79.2	87.1	102.7	114.4	123.5	132.2	138.8	143.8	147.5
	50	45.0	53.2	59.3	64.1	68.7	72.2	74.8	76.8	83.8	99.0	110.4	119.3	127.8	134.4	139.3	142.9
R407C	-40	50.4	57.3	61.9	65.1	67.9	69.6	70.6	71.0	93.9	106.6	115.2	121.2	126.4	129.6	131.5	132.2
	-20	50.4	57.6	62.5	66.0	69.1	71.1	72.4	73.0	93.8	107.2	116.4	122.9	128.7	132.4	134.7	135.9
	0	49.7	57.2	62.5	66.3	69.6	71.9	73.4	74.2	92.6	106.6	116.3	123.4	129.6	133.9	136.6	138.2
	20	48.5	56.2	61.7	65.7	69.3	71.8	73.5	74.6	90.4	104.7	114.9	122.3	129.1	133.8	136.9	138.8
	40	46.8	54.6	60.1	64.3	68.1	70.8	72.7	73.9	87.1	101.6	111.9	119.7	126.8	131.8	135.3	137.5
	50	45.7	53.5	59.0	63.2	67.1	69.9	71.8	73.1	85.2	99.5	109.9	117.7	125.0	130.1	133.7	136.1
R22	-40	48.5	55.6	60.6	64.3	67.7	70.1	71.8	72.9	90.3	103.6	112.9	119.8	126.1	130.5	133.7	135.7
	-20	48.1	55.5	60.8	64.7	68.3	70.9	72.8	74.0	89.6	103.4	113.1	120.4	127.2	132.0	135.5	137.8
	0	47.3	54.9	60.3	64.4	68.2	71.0	73.1	74.5	88.1	102.2	112.3	119.9	127.1	132.3	136.0	138.7
	20	46.0	53.6	59.2	63.5	67.5	70.4	72.6	74.1	85.6	99.9	110.3	118.1	125.6	131.1	135.1	138.0
	40	44.2	51.9	57.5	61.8	65.9	68.9	71.2	72.9	82.3	96.6	107.0	115.0	122.7	128.4	132.6	135.7
	50	43.2	50.8	56.4	60.7	64.8	67.9	70.2	71.9	80.4	94.5	104.9	112.9	120.6	126.4	130.7	133.8
R134a	-40	41.8	46.4	49.2	50.9	51.9	52.2	51.8	50.9	77.7	86.4	91.6	94.7	96.7	97.1	96.4	94.8
	-20	42.3	47.3	50.4	52.4	53.8	54.2	54.1	53.4	78.7	88.1	93.9	97.6	100.1	101.0	100.7	99.5
	0	42.3	47.7	51.1	53.4	55.1	55.8	55.9	55.5	78.7	88.8	95.2	99.4	102.5	103.9	104.1	103.3
	20	41.8	47.5	51.3	53.8	55.7	56.7	57.0	56.8	77.8	88.5	95.4	100.1	103.7	105.6	106.2	105.8
	40	40.8	46.7	50.7	53.4	55.6	56.9	57.4	57.4	75.9	87.0	94.4	99.5	103.6	105.9	106.9	106.8
	50	40.1	46.1	50.1	53.0	55.3	56.6	57.2	57.3	74.6	85.8	93.4	98.6	102.9	105.4	106.6	106.7
R404A	-40	37.9	42.6	45.6	47.4	48.6	49.0	48.9	48.2	70.6	79.4	84.8	88.2	90.5	91.3	91.0	89.8
	-20	37.5	42.5	45.7	47.8	49.3	50.0	50.0	49.6	69.9	79.2	85.1	89.0	91.8	93.0	93.1	92.3
	0	36.6	41.8	45.2	47.5	49.2	50.1	50.4	50.1	68.1	77.8	84.2	88.4	91.7	93.3	93.8	93.3
	20	35.2	40.5	44.0	46.4	48.4	49.4	49.8	49.7	65.5	75.3	81.9	86.4	90.1	92.0	92.8	92.6
	40	33.3	38.5	42.1	44.6	46.6	47.8	48.3	48.3	62.0	71.7	78.4	83.0	86.8	89.0	90.0	89.9
	50	32.2	37.3	40.9	43.4	45.4	46.6	47.2	47.2	59.9	69.5	76.1	80.7	84.6	86.8	87.8	87.8

The capacities stated in the tables are for the normal flow direction. For ETS 50 and 100 specifically, the capacity in reverse flow direction varies between 90% and 125% of the capacity in normal flow direction.

Data sheet | Electric expansion valve, type ETS 12.5 – ETS 400

Rated Capacity [TR]
(TR = ton of refrigeration)

US units

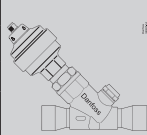
	t_e [°F]	Rated capacity [TR] in the normal flow direction															
		ETS 250								ETS 400							
		Pressure drop Δp [psi]															
		40	60	80	100	125	150	175	200	40	60	80	100	125	150	175	200
R407C	-40	258	292	315	331	344	351	355	356	411	466	502	527	548	561	567	568
	-20	257	293	318	335	350	359	364	366	410	468	507	535	558	573	581	584
	0	254	292	317	336	352	363	369	372	405	465	506	536	562	579	589	594
	20	247	286	313	333	350	362	369	374	395	456	499	531	559	577	589	596
	40	238	277	305	325	343	356	364	369	380	442	486	518	548	568	581	589
	50	232	271	299	319	338	351	360	365	371	432	476	509	539	560	574	582
R22	-40	250	286	312	331	348	361	369	375	398	456	497	528	556	575	589	598
	-20	248	286	313	333	351	365	374	381	395	455	499	531	560	582	597	607
	0	243	282	310	331	351	365	376	383	388	450	495	528	560	583	599	611
	20	236	276	305	326	347	362	373	381	377	440	486	521	553	578	595	608
	40	227	267	296	318	339	355	366	375	363	425	471	507	540	566	584	598
	50	222	261	290	312	333	349	361	370	354	416	462	498	531	557	576	590
R134a	-40	215	239	253	262	267	268	266	262	342	381	404	417	426	428	425	418
	-20	217	243	259	269	276	279	278	275	347	388	414	430	441	445	444	439
	0	217	245	263	275	283	287	288	285	347	391	420	438	452	458	459	455
	20	215	244	264	276	286	292	293	292	343	390	420	441	457	465	468	466
	40	210	240	261	275	286	292	295	295	334	383	416	438	456	466	471	470
	50	206	237	258	272	284	291	294	295	329	378	411	434	453	464	469	470
R404A	-40	195	219	234	243	249	252	251	247	311	349	373	388	398	401	400	394
	-20	193	218	235	245	253	256	256	254	307	348	374	391	403	409	409	405
	0	188	215	232	244	253	257	258	257	300	342	370	389	403	410	412	410
	20	181	208	226	238	248	253	256	255	288	331	360	380	396	404	408	406
	40	171	198	216	229	239	245	248	247	273	315	344	365	381	391	395	395
	50	165	192	210	222	233	239	242	242	263	306	334	355	371	381	385	385

Data sheet | Electric expansion valve, type ETS 12.5 – ETS 400

Capacity
Normal flow direction

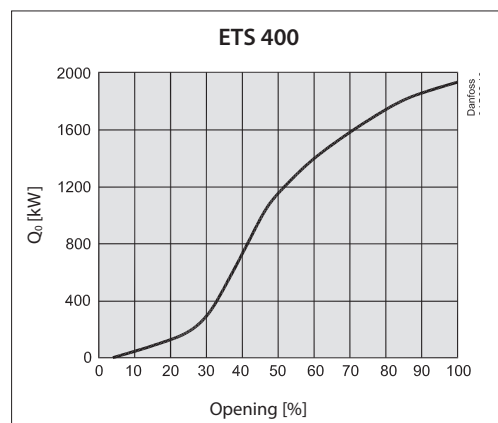
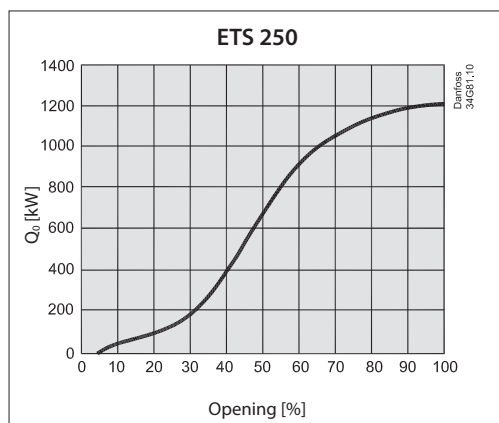
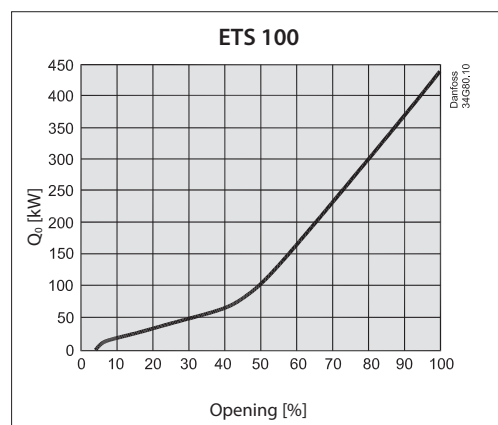
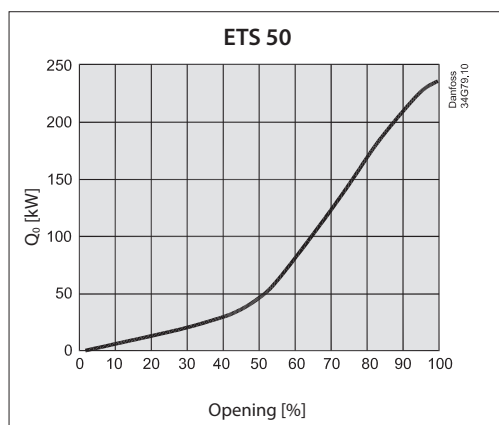
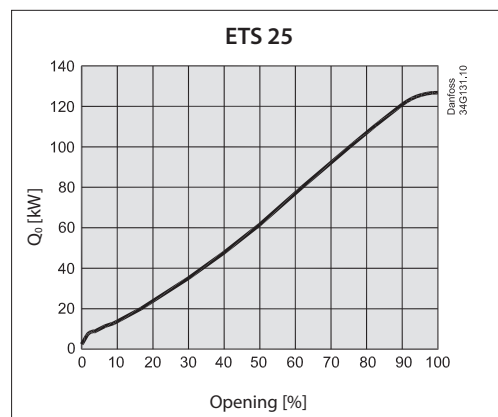
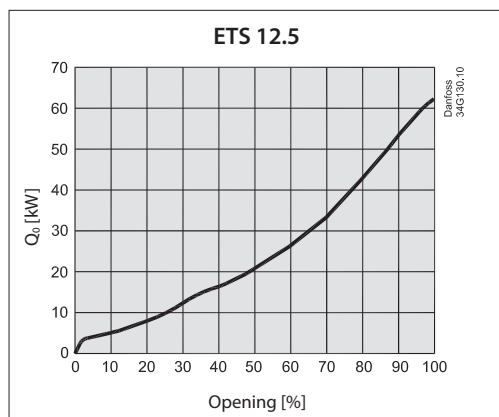

Capacity based on: R407C
 $T_e = 5\text{ °C} / 41\text{ °F}$
 $T_c = 32\text{ °C} / 89.6\text{ °F}$
 $T_l = 28\text{ °C} / 82.4\text{ °F}$

Data sheet | Electric expansion valve, type ETS 12.5 – ETS 400

Dimensions and weights for ETS 12.5 and ETS 25

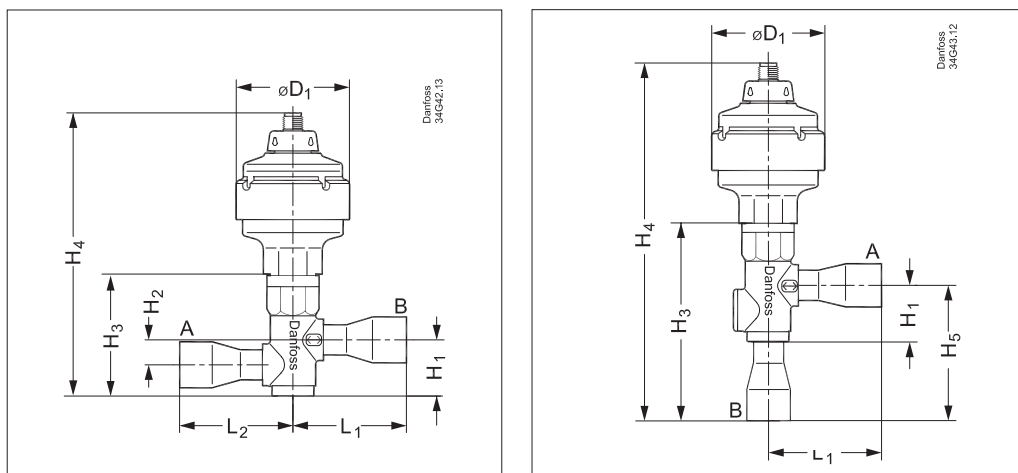

Type	Connections		H ₁		H ₂		H ₃		H ₄		H ₅		L ₁		L ₂		øD ₁		Net weight	
	ODF × ODF (A × B)		[in.]	[mm]	[in.]	[mm]	[in.]	[mm]	[in.]	[mm]	[in.]	[mm]	[in.]	[mm]	[in.]	[mm]	[in.]	[mm]	[kg]	[lb.]
	[in.]	[mm]																		
ETS 12.5 and 25 straight	½ × ½	12 × 12	1.2	30	0.5	13	2.5	64	5.9	150	-	-	2.4	60	2.4	60	2.4	60	0.7	1.5
	⅝ × ⅝	16 × 16	1.2	30	0.5	13	2.5	64	5.9	150	-	-	2.4	60	2.4	60	2.4	60	0.7	1.5
	⅞ × ⅞	22 × 22	1.2	30	0.5	13	2.5	64	5.9	150	-	-	2.4	60	2.4	60	2.4	60	0.7	1.5
ETS 12.5 and 25 angle	½ × ½	12 × 12	1.2	30	-	-	2.5	64	7.6	194	2.9	74	2.4	60	-	-	2.4	60	0.7	1.5
	⅝ × ⅝	16 × 16	1.2	30	-	-	2.5	64	7.6	194	2.9	74	2.4	60	-	-	2.4	60	0.7	1.5
	⅞ × ⅞	22 × 22	1.2	30	-	-	2.5	64	7.6	194	2.9	74	2.4	60	-	-	2.4	60	0.7	1.5

Dimensions and weights for ETS 50 and ETS 100

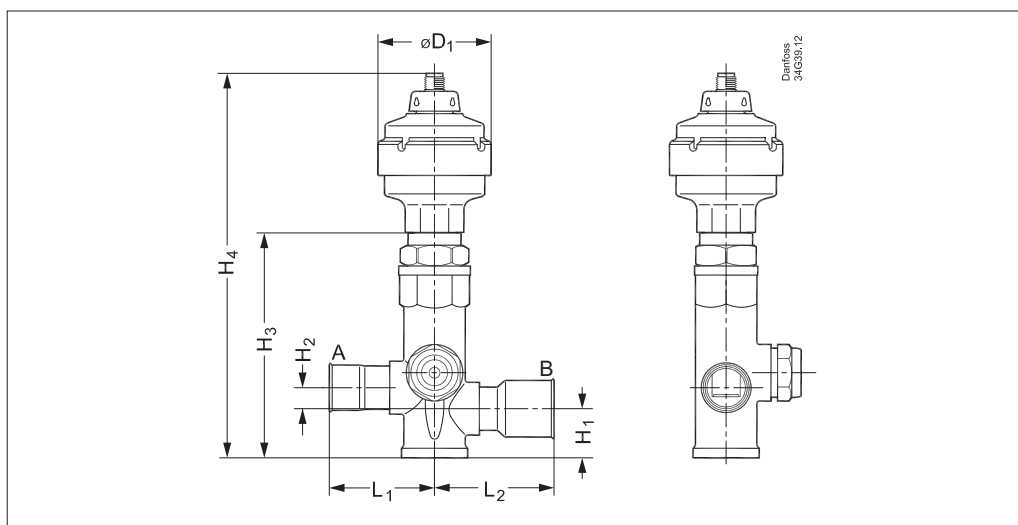

Type	Connections		H ₁		H ₂		H ₃		H ₄		L ₁		L ₂		øD ₁		Net weight	
	ODF × ODF (A × B)		[in.]	[mm]	[in.]	[mm]	[in.]	[mm]	[in.]	[mm]	[in.]	[mm]	[in.]	[mm]	[in.]	[mm]	[kg]	[lb.]
	[in.]	[mm]																
ETS 50	⅞ × ⅞	22 × 22	1.0	26.2	0.5	13.0	4.7	118.0	8.1	205.0	2.2	56.0	2.2	56.0	2.4	60.0	1.5	3.3
	⅞ × 1⅛	22 × 28	1.0	26.2	0.5	13.0	4.7	118.0	8.1	205.0	2.2	56.0	2.5	63.0	2.4	60.0	1.5	3.3
	1⅛ × 1⅛	28 × 28	1.0	26.2	0.5	13.0	4.7	118.0	8.1	205.0	2.5	63.0	2.5	63.0	2.4	60.0	1.5	3.3
	1⅛ × 1⅜	28 × 35	1.0	26.2	0.5	13.0	4.7	118.0	8.1	205.0	2.5	63.0	2.9	74.0	2.4	60.0	1.5	3.3
ETS 100	1⅛ × 1⅛	28 × 28	1.2	30.0	0.7	17.0	5.0	127.0	8.4	214.0	2.6	66.0	2.6	66.0	2.4	60.0	1.7	3.7
	1⅛ × 1⅜	28 × 35	1.2	30.0	0.7	17.0	5.0	127.0	8.4	214.0	2.6	66.0	3.0	76.0	2.4	60.0	1.7	3.7
	1⅜ × 1⅜	35 × 35	1.2	30.0	0.7	17.0	5.0	127.0	8.4	214.0	3.0	76.0	3.0	76.0	2.4	60.0	1.7	3.7
	1⅝ × 1⅝	-	1.2	30.0	0.7	17.0	5.0	127.0	8.4	214.0	3.3	84.0	3.3	84.0	2.4	60.0	1.7	3.7

**Dimensions and weights for
ETS 250 and ETS 400**

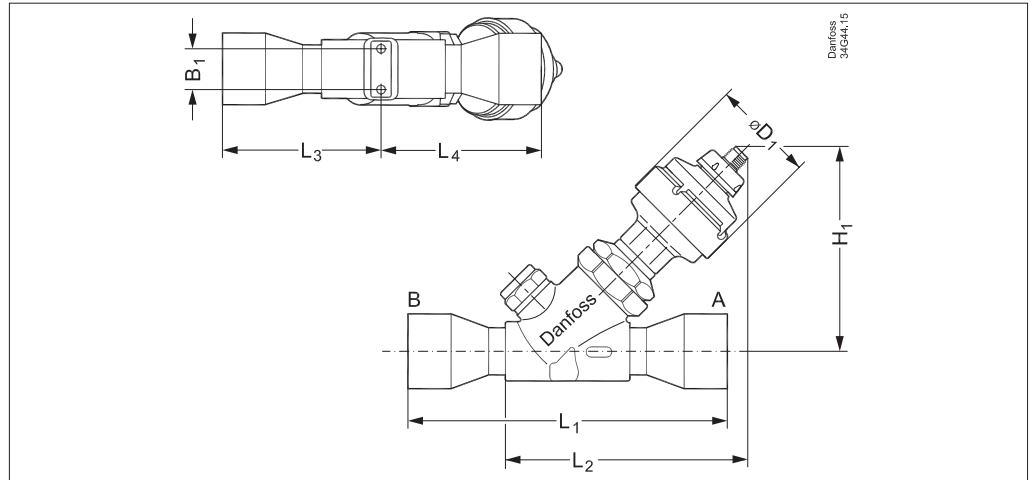

Type	Connections		H ₁		L ₁		L ₂		L ₃		L ₄		øD ₁		B ₁		Net weight	
	ODF × ODF (A × B)		[in.]	[mm]	[in.]	[mm]	[in.]	[mm]	[in.]	[mm]	[in.]	[mm]	[in.]	[mm]	[in.]	[mm]	[kg]	[lb.]
	[in.]	[mm]																
ETS 250	1 ¹ / ₈ × 1 ¹ / ₈	28 × 28	4.7	120.0	6.7	168.5	5.6	143.0	3.3	83.0	3.4	85.5	2.4	60.0	0.95	24.0	1.9	4.2
	1 ³ / ₈ × 1 ³ / ₈	35 × 35	4.7	120.0	7.0	178.5	5.6	143.0	3.5	88.0	3.6	90.5	2.4	60.0	0.95	24.0	1.9	4.2
	1 ⁵ / ₈ × 1 ⁵ / ₈	–	4.7	120.0	7.4	188.5	5.6	143.0	3.7	93.0	3.8	95.5	2.4	60.0	0.95	24.0	1.9	4.2
	–	42 × 42	4.7	120.0	7.4	188.5	5.6	143.0	3.7	93.0	3.8	95.5	2.4	60.0	0.95	24.0	1.9	–
ETS 400	1 ⁵ / ₈ × 1 ⁵ / ₈	–	4.8	121.0	8.0	203.0	5.7	144.5	3.9	99.0	4.1	104.0	2.4	60.0	0.95	24.0	2.2	4.9
	2 ¹ / ₈ × 2 ¹ / ₈	54 × 54	4.8	121.0	9.6	243.0	5.7	144.5	4.7	119.0	4.9	124.0	2.4	60.0	0.95	24.0	2.2	4.9

Related products

EKE 1A, EKE 1B, EKE 1C	EKS 221, ACCPBT, AKS 11/AKS 12	AKS 32R, AKS 33, NSK	AST-G
Superheat controller	Temperature sensor	Pressure transmitter	Service driver Code no. 034G0013

All Danfoss products fulfill the requirements in REACH.

One of the obligations in REACH is to inform customers about presence of Candidate list substances if any, we hereby inform you about one substance on the candidate list: A moist indicator in the sight glass contains a paper which is impregnated with Cobalt Dichloride (CAS no: 7646-79-9) in a concentration above 0.1% w/w.
- Avoid skin contact with the paper - Do not inhale the dust from the paper - The paper must be disposed as hazardous waste.

Danfoss can accept no responsibility for possible errors in catalogues, brochures and other printed material. Danfoss reserves the right to alter its products without notice. This also applies to products already on order provided that such alterations can be made without consequential changes being necessary in specifications already agreed. All trademarks in this material are property of the respective companies. Danfoss and the Danfoss logotype are trademarks of Danfoss A/S. All rights reserved.